

HMD-402

Anti-Theft Wall-Mounted/Countertop Tablet Holder

hamood



Wall Mountable
for various applications



Locking Mechanism with Key
protection from theft or vandalism

Innovative Enclosure Design

Two Adjustable Claws
securely hold the tablet

EVA Foam + Silicone Pads
protect devices from scratches and damage

Cable Cutout
for charging and wire management

Six Tablet Panels Included
for different sized tablets



Material
Steel, Plastic



Color
Matte White, Matte Black



Weight Capacity
1kg (2.2lbs)



Screen Rotation
0°~+90°



Dimensions
343x206x186mm
(13.5"x8.1"x7.3")



Fit Screen Size
iPad Pro(9.7"; 10.5"; 11"), Samsung Galaxy Tab A 10.1 (2019), Samsung Galaxy Tab S6 Lite 10.4", iPad 6, iPad 9, Samsung Galaxy Tab A7, iPad 8, iPad Air(9.7"; 10.5"; 10.9"), iPad 7, iPad 5, iPad 10 (10.9")

HMD-402

Anti-Theft Wall-Mounted/Countertop Tablet Holder

hamood



DESCRIPTION

HMD-402 is a versatile tablet holder that is wall-mounted or installed on countertop surfaces. The enclosure can be rotated for horizontal or vertical viewing. An innovative internal design creates an all-in-one enclosure - compatible with most 9.7" to 11" tablets including iPad, iPad Air, iPad Pro, Samsung Galaxy Tab A, Tab A7 & Tab S6 Lite. Featuring an anti-theft lock and durable steel construction, it is safe and durable for high-traffic areas and public use.



Dimensions (mm)



Functionally Versatile
landscape or portrait

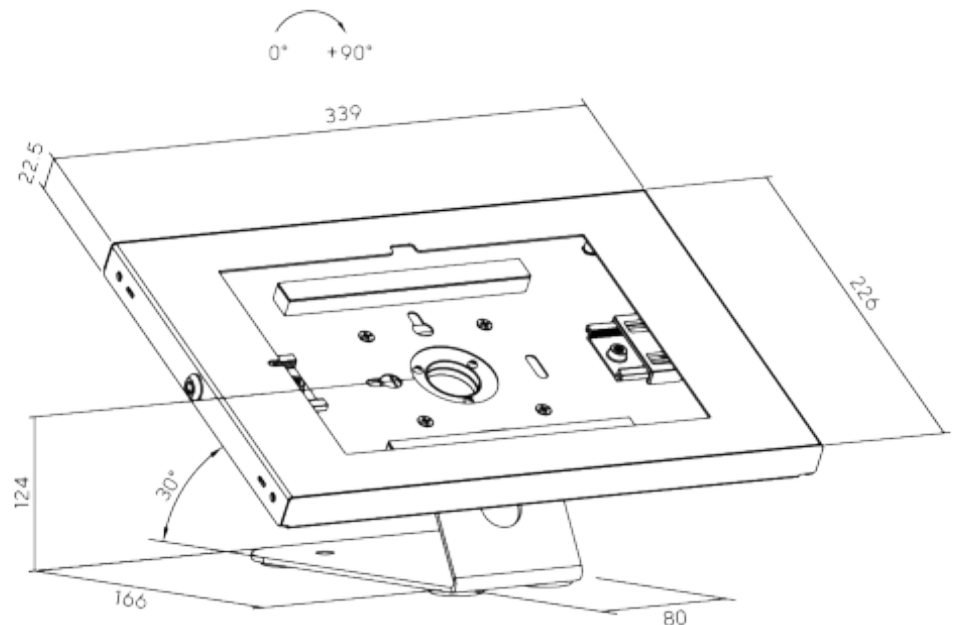

FEATURES

- Anti-Skid pads prevent scratches or scuffs
- 90° Rotation: for easily holding your iPad in portrait or landscape orientation
- Anti-theft Lock with a Key: for additional security preventing any unwanted removal in the public
- VESA Compatible: supports mounted on panel with standard VESA holes

<https://hamoodtv.com>