

# HAM-107

DUAL MONITORS POLE-MOUNTED GAS SPRING MONITOR ARM

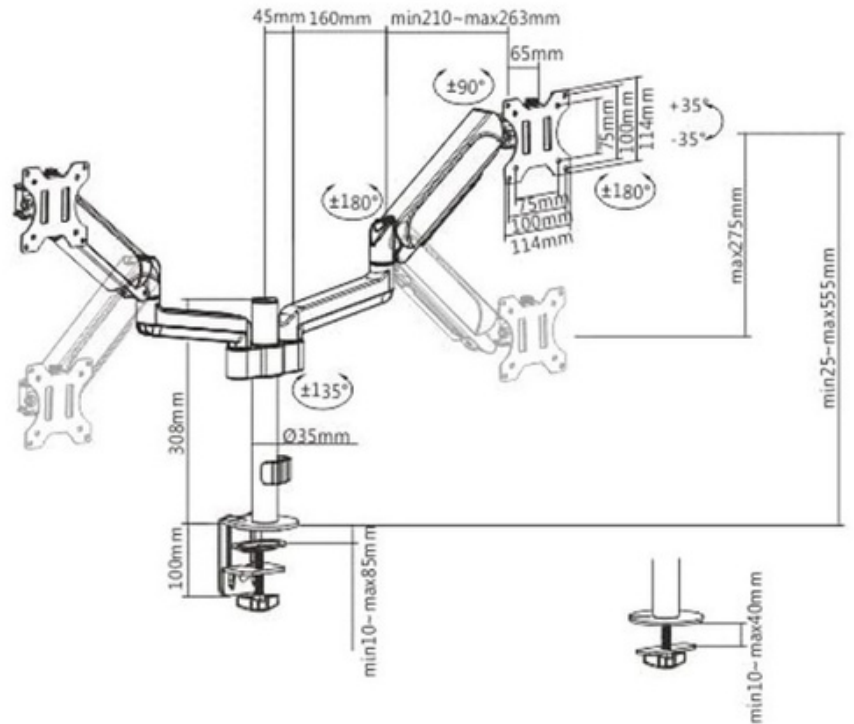

**Fit Screen Size**  
17"-32"

**Weight Capacity**  
1~9kg

**VESA Compatible**  
75x75,100x100

**Tilt Range**  
+35°~-35°

**Swivel Range**  
+90°~-90°



**Built-in Cable Management**  
keeps wires organized for a clean look

**Cable Management**



**Detachable VESA Plate**  
makes installation a click

**360° Rotary VESA Plate**



**Detachable VESA Plate Design**